

Thr3e

ORION



Design
Stramigioli
Associati

Thr3e rappresenta il prodotto con cui Orion chiude la presentazione delle vetrine dedicate alla conservazione dei prodotti alimentari.

Orion entra nel mercato del food retail con prodotti che non passano mai inosservati, soprattutto perché contraddistinti da un "family feeling" riconoscibile e unico.

Thr3e è il nuovo piccolo gioiello perfettamente adattabile a qualsiasi locale perché Compatto, Innovativo e Flessibile. Tecnologia smart per un'esposizione senza confronti, lasciando liberi i clienti di sfruttare al meglio gli spazi all'interno del proprio negozio grazie alle due versioni in gamma:

Grab'n Go per agevolare il libero servizio dei prodotti già incartati tra cui il cliente può scegliere.

Service per gli acquisti guidati dalle preziose indicazioni dell'operatore.

Thr3e

Compatta, Innovativa
e Flessibile.

**Thr3e la piccola grande
vetrina di Orion.**

A compact, innovative
and flexible showcase.

Thr3e is our little big showcase by Orion.

Thr3e is the product with which Orion closes the presentation of the showcases dedicated to preserving foods and food-related products.

Orion enters the food retail market with brand-new outstanding products, since they stand out for their one-of-a-kind and easily recognizable "family feeling".

Thr3e is our new little jewel which can perfectly adapt to each premise being it compact, innovative and flexible. It also boasts a smart technology to ensure an unprecedented exposure by enabling our clients to best use the internal space inside the premises thanks to the two versions included in the product range:

Grab'n Go fosters the free take-away of the wrapped products for the clients to choose.

Service to buy the suggested products according to the operator's suggestions.

Libero servizio, con Stile.

A stylish free take-away.

02

Design minimale e distintivo, Thr3e si inserisce con stile tra i prodotti dedicati al libero servizio nei locali food.

Una vetrina compatta con una schiena completamente refrigerata, in cui i prodotti sono perfettamente conservati e visibili al consumatore che è libero di scegliere, prendere ed acquistare.

Thanks to its minimal and outstanding design, Thr3e is one of the stylish products dedicated to the free take-away to be found in the food-related premises.

It is a compact showcase with a completely refrigerated rear panel, in which the products can be perfectly preserved while remaining clearly visible for the customer to freely choose, take and purchase them.



03

Thr3e
Grab'n Go

Tecnologia a servizio della funzionalità.

Technology merging into functionality.



Ogni prodotto esposto nella versione Grab'n Go di Thr3e è perfettamente conservato, facilmente accessibile e ben visibile. Esposizione che diventa esaltazione, con un focus particolare a tutti gli acquisti che vengono fatti d'impulso.

Each product to be showcased in the Grab'Go version is perfectly preserved, to be easily accessed while keeping the products clearly visible. Showcasing the products means enhancing them particularly focusing on all the purchases to be impulsively made.

04



Spazio alla flessibilità.

A new flexibility.

Due lunghezze disponibili nella versione Grab'n Go, da accostare in modo lineare per creare un'esposizione continua di prodotti all'interno del locale.

Libere di arredare spazi diversi in un unico ambiente, contenitori di prodotti diversi, ma funzionali perché visibili ed accessibili nello stesso modo.

The range includes two available lengths for the Grab'n Go version, to be matched in a linear way to create a continuous showcasing for the products to be served in the premise.

The customers can freely design their premises to create a one-of-a-kind atmosphere, in order to showcase various products without forgetting to design a functional premise to make the products visible and accessible.

Raccontare un prodotto esponendolo.

How to describe and showcase a product.

06

Il consumatore è sempre più esigente, spesso distratto e immerso in acquisti phygital, tra il punto vendita e l'online. Imperativo per ogni punto vendita è conquistarlo, Thr3e assolve a questo compito perché adattabile a diverse tipologie di locali.

Refrigerazione ventilata, spalle in vetro camera, illuminazione led e visibilità senza confronti queste le caratteristiche che rendono Thr3e ideale per l'esposizione di un'ampia gamma di prodotti.

The consumer is becoming more and more demanding, is often distracted and busy in phygital purchases between the sales point and the online sales. Capturing the consumers' attention is essential for each sales point and Thr3e perfectly fulfils the expectations since it can adapt to various kinds of premises.

It boasts a ventilated refrigeration system, glass end side panels, LED lighting and a one-of-a-kind visibility: all these features make Thr3e the ideal showcase to showcase a wide range of products.



CAFFETTERIE
COFFEE SHOP



MERCATO DI QUARTIERE
NEIGHBORHOOD FOOD MARKET



HUB DI VIAGGIO
TRAVEL HUB



STAZIONI DI SERVIZIO
SERVICE STATION



Servito e soddisfatto, grazie ad una visibilità estrema

An extreme visibility to serve and satisfy the customers.

08



Design minimale e distintivo, anche per la versione Service di Thr3e che permette all'operatore un servizio agevole al consumatore, che sceglie tra i prodotti esposti grazie ad un sistema di esposizione accogliente, in cui tutto è perfettamente visibile.

Una vetrina compatta con ampie superfici vetrate, che garantendo l'esaltazione dei prodotti esposti stimolano i sensi del consumatore.

Thanks to the minimal and outstanding design, also the Service version enables the operators to easily serve the consumers, who chooses among the showcased products thanks to a welcoming showcasing system marking all the products clearly visible.

It is a compact showcase with wide glass surfaces enhancing the showcased products while stimulating the consumers' senses to guide the consumers into an aware purchase.

09

Thr3e
Service



Accessibile e funzionale.

Accessibility and functionality.

Nell'arco della giornata l'operatore compie gesti e movimenti ripetitivi, Thr3e Service permette che questi possano essere svolti in modo consapevole, rendendo il servizio al cliente fluido, ma anche le operazioni di carico della vetrina sono altrettanto semplici e veloci.

A seconda del tipo di prodotto che viene esposto, l'addetto alla vendita ha la possibilità di allestire la vetrina in modo da rispondere alle esigenze più particolari, accedendo ai ripiani grazie a comode porte in vetro camera che scorrono su ruote con chiusura assistita.

During the day the operator carries out repetitive gestures and movements, Thr3e Service enables the operator to carry them out being aware of their meaning while making the service fluid and the showcases' loading operations easier and faster.

According to the type of product to showcase, the sales operator can design the windows as to satisfy all the particular expectations, in order to access the tops thanks to the comfortable glass doors sliding on wheels with assisted closure.

Compatta, ma di Design.

A compact and designed showcase.

10

Le linee pulite del frontale esaltano il design estremamente moderno e sofisticato della versione Service di Thr3e. La particolare sagomatura delle spalle terminali, le linee morbide del frontale rappresentano i must di questa proposta compatta dedicata al mondo del food retail.

L'equilibrio di componenti, volumi e proporzioni permette l'accostamento dei moduli creando linee espositive modulabili che arredano lo spazio con soluzioni innovative.

The clear front shapes enhance the extremely modern and sophisticated design for the Service version. The peculiar shape of the end side panels and the soft front shapes are the essential features of this compact showcase dedicated to the food retail world.

The balance among the components, volumes and proportions enable the clients to match the modules while creating modular shapes which design the space with innovative solutions.



Esaltare i prodotti esposti.

Enhancing the showcased products.

Chi sceglie Thr3e Service sa di poter presentare e conservare nel modo migliore i prodotti caratteristici del mondo del food retail.

Visibilità estrema al servizio di una capienza senza paragoni, garantendo una tecnologia che rispecchia le performance conosciute ed apprezzate da sempre dai nostri clienti.

The clients who choose Thr3e Service know they can best present and preserve their typical products in the food retail field

Thanks to its extreme visibility ensuring the unprecedented widest capacity, this showcase ensures a technology reflecting the already known performances which have always been appreciated by our customers.



PASTICCERIE
PASTRY SHOP



CAFFETTERIE
COFFEE SHOP



MERCATO DI QUARTIERE
NEIGHBORHOOD FOOD MARKET



HUB DI VIAGGIO
TRAVEL HUB



Gamma

Range

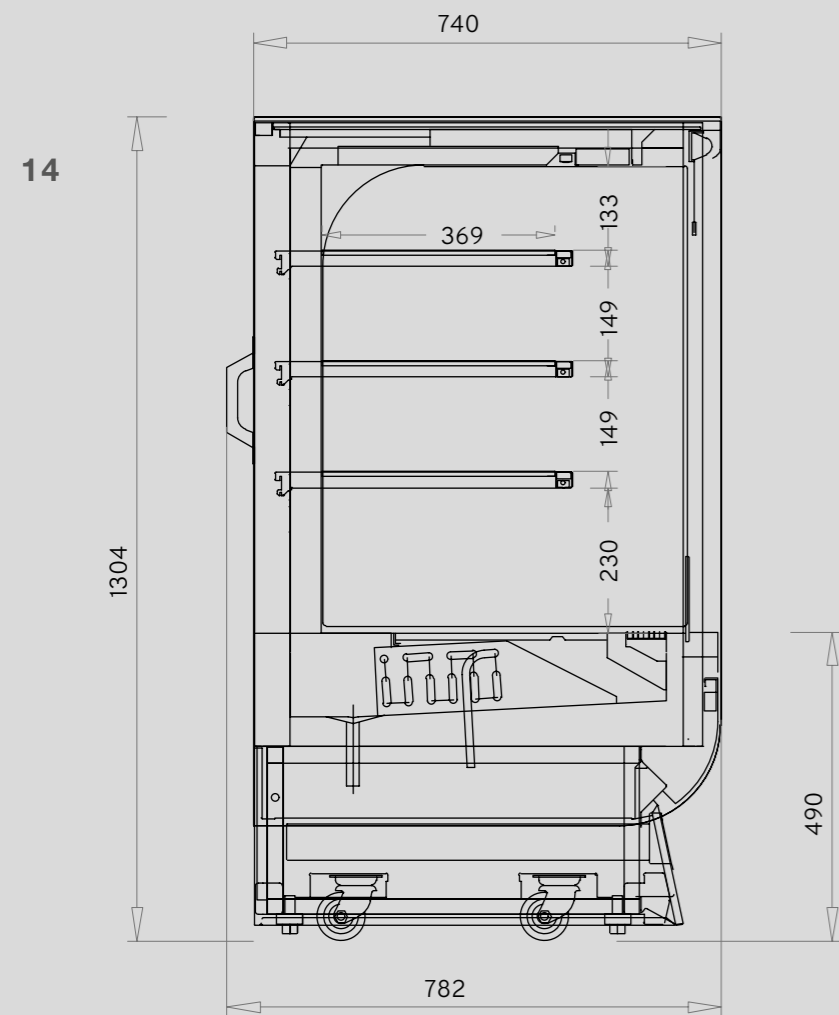

THR3E GRAB'N GO T+ V +2°/+4° Temperatura Positiva Ventilata

VENTILATED POSITIVE TEMPERATURE

Vetrina Tr3e VERSIONE GRAB'N GO con refrigerazione ventilata. Unità interna ad Aria, illuminazione led sul tettino e mensole. Spalle terminali in vetro camera Con serigrafia RAL 7022. Rivestimento frontale, zoccolo frontale e laterale vano motore INCLUSI. personalizzabili RAL 9005 o RAL 9010, altri colori RAL optional. Zoccolo Laterale vano motore RAL 7022. Maniglie sul retro e ruote per la movimentazione. Tendina notte per la chiusura del vano espositivo.

Showcase Tr3e VERSIONE GRAB'N GO with a ventilated refrigeration system. Internal air-cooled unit, LED lighting on the top glass and on the shelves. Glass end side panels with a serigraphy painted in RAL 7022. Front covering, front and side plinth for the engine compartment included. To be customized as RAL 9005 or RAL 9010, other RAL colours are optional. Side plinth for the engine compartment in RAL 7022. Rear handles and movable wheels. Night curtain for closing the showcasing compartment.

MODULI MODULES

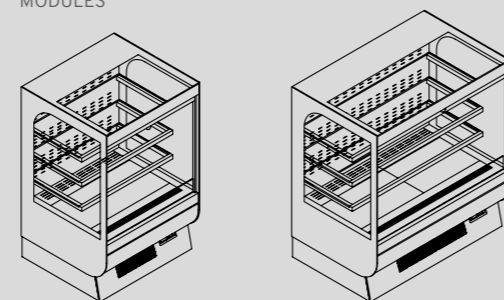

L. 900

L. 1200

PIANTE DRAWINGS

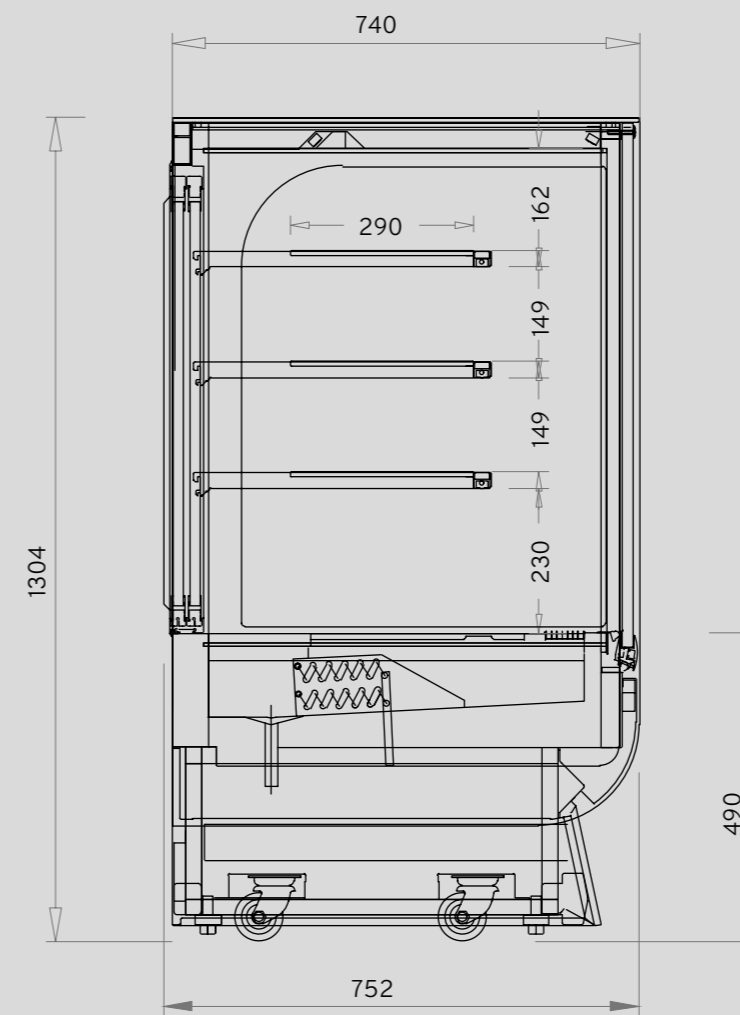
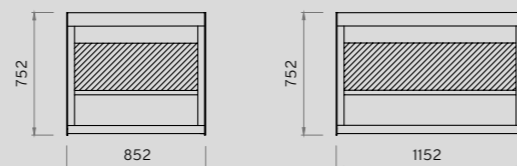

THR3E SERVICE T+ V +4°/+8° Temperatura Positiva Ventilata

VENTILATED POSITIVE TEMPERATURE

Vetrina Tr3e VERSIONE SERVICE con refrigerazione ventilata. Unità interna ad Aria, illuminazione led sul tettino e mensole. Spalle terminali in vetro camera Con serigrafia RAL 7022. Accesso all'area espositiva tramite porte in vetro camera scorrevoli, chiusura assistita con cerniera. Rivestimento frontale, zoccolo frontale e laterale vano motore INCLUSI. Personalizzabili RAL 9005 o RAL 9010, altri colori RAL optional. Zoccolo Laterale vano motore RAL 7022. Ruote per la movimentazione.

Showcase Tr3e VERSIONE SERVICE with a ventilated refrigeration system. Internal air-cooled unit, LED lighting on the top glass and on the shelves. Glass end side panels with serigraphy in RAL 7022. The showcasing compartment is accessible through sliding glass doors with assisted closure by means of a hinge. Front covering, front and side plinth for the engine compartment included. To be customized as RAL 9005 or RAL 9010, other RAL colours are optional. Front plinth for the engine compartment RAL 7022. Movable wheels.

MODULI MODULES

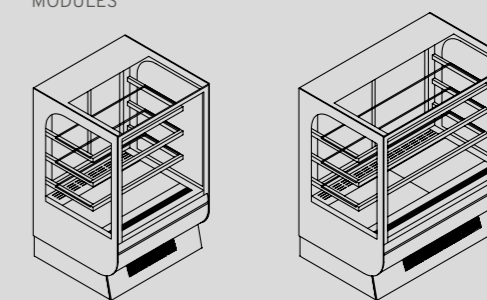

L. 900

L. 1200

PIANTE DRAWINGS

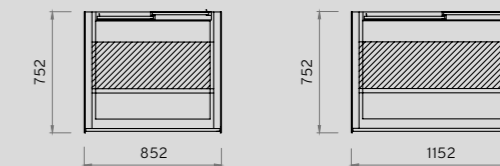

*Orion si riserva il diritto di apportare modifiche ai prodotti illustrati in questo catalogo, in qualunque momento senza l'obbligo di preavviso.
Le finiture riprodotte in questo catalogo sono indicative per le inevitabili differenze dovute alla riproduzione tipografica.*

*Orion reserves the right to make modifications to the products shown in this catalogue at any time without prior notice.
The finishings shown in this catalogue are approximate, as a printed reproduction causes inevitable colour differences.*

© ORION

*I prodotti possono essere tutelati da brevetto e/o da design.
Tutti i diritti riservati*

*Products may be protected by patent and/or design.
All rights reserved.*

ORION

ORION
VIALE DELL'INDUSTRIA 15
60035 JESI (AN)
ITALY

PHONE: +39 0731 61531
FAX: +39 0731 6153413

INFO@ORIONSTYLE.COM
WWW.ORIONSTYLE.COM

EDIZIONE OTTOBRE 2021

Hanno collaborato
alla realizzazione
di questo catalogo:

Art Direction/Graphic Design
UP STUDIO
Prepress
MIC STUDIO
Print
GRAPHO 5



www.orionstyle.com

ORION